

CCN Report  
Modelling Emotion at a Neuronal Level

Samantha Lam  
s0790004  
School of Informatics  
University of Edinburgh

Instructor: Dr Peggy Seriès

April 6, 2008



# Contents

<b>1</b>	<b>Introduction</b>	<b>3</b>
<b>2</b>	<b>Emotional Memory</b>	<b>4</b>
<b>3</b>	<b>Models of Emotion</b>	<b>5</b>
3.1	A Simple High-level Model of Cortical Areas associated with Emotions . . . . .	5
3.2	Low-level Models . . . . .	5
3.2.1	A Generic Neural Network Model . . . . .	5
3.2.2	Adapted to Emotion as a Motivator of Behaviour . . . . .	5
<b>4</b>	<b>Discussion</b>	<b>6</b>

# 1 Introduction

What report's about.

## **2 Emotional Memory**

(Hamann, 2001; LeDoux, 1993) - Background/History of Emotional Memory, the case for its existence.

### 3 Models of Emotion

#### 3.1 A Simple High-level Model of Cortical Areas associated with Emotions

(Moren & C., 2000)'s model

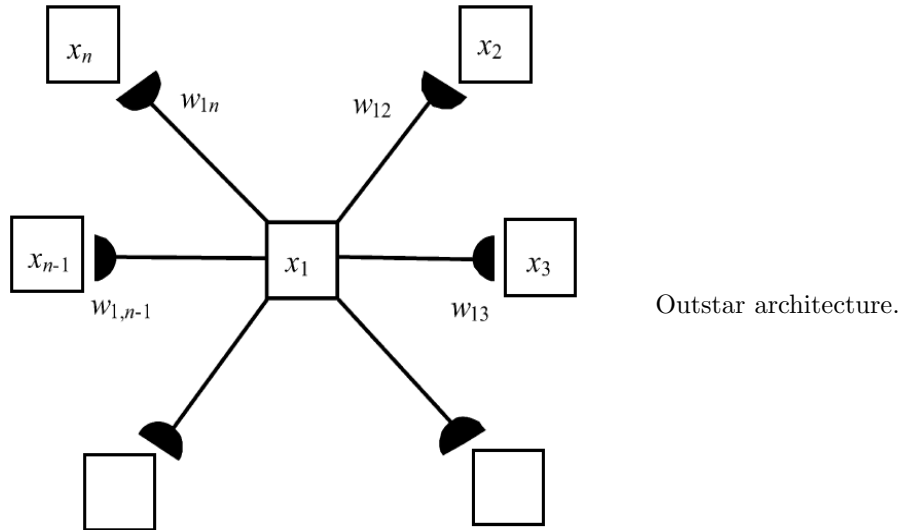

Figure 1: Outstar architecture.

$$\begin{aligned} \frac{dx_1}{dt} &= -ax_1 + I_1, \\ \frac{dx_i}{dt} &= -ax_i + bx_1w_{1i} + I_i, i = 2, \dots, n, \\ \frac{dw_{1i}}{dt} &= x_1(-cw_{1i} + x_i), i = 2, \dots, n. \end{aligned}$$

#### 3.2 Low-level Models

##### 3.2.1 A Generic Neural Network Model

##### 3.2.2 Adapted to Emotion as a Motivator of Behaviour

Levine's model

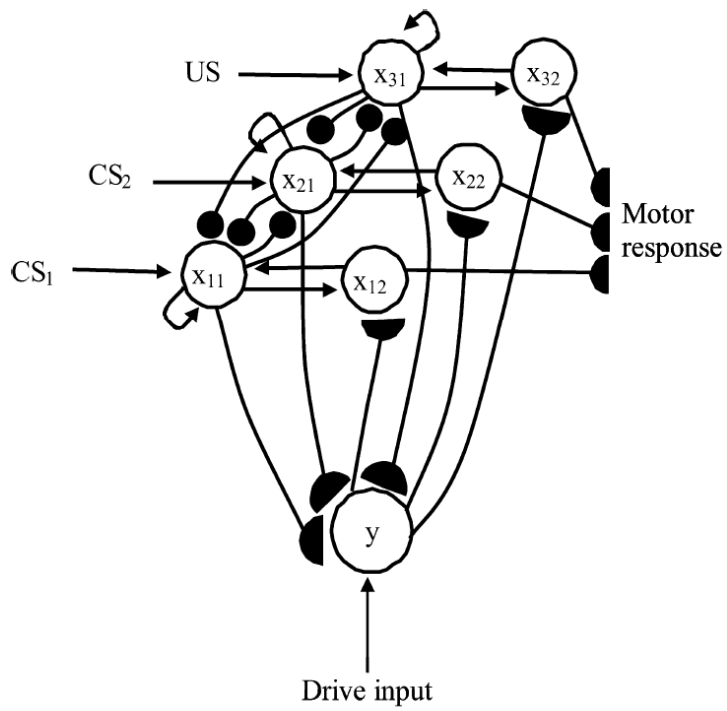

Network used to simulate attentional effects in Pavlovian conditioning.

Figure 2: Pavlovian conditioning neural network architecture.

## 4 Discussion

## References

- Hamann, S. (2001). Cognitive and neural mechanisms of emotional memory. *TRENDS in Cognitive Sciences*, 5(9), 394–400.
- LeDoux, J. E. (1993). Emotional memory systems in the brain. *Behavioural Brain Research*, 58, 69–79.
- Levine, D. (2007). Neural network modeling of emotion. *Physics of Life Reviews*, 4(1), 37–63.
- Moren, J. & C., B. (2000). A Computational Model of Emotional Learning in the Amygdala. *From Animals to Animats 6: Proceedings of the Sixth International Conference on Simulation of Adaptive Behavior*, 1, 4.
- Panksepp, J. (2003). At the interface of the affective, behavioral, and cognitive neurosciences: Decoding the emotional feelings of the brain. *Brain and Cognition*, 52(1), 4–14.